

Lyapunov theory based robust control of complicated nonlinear mechanical systems with uncertainty[†]

Hyun Cheol Cho¹, Jin Woo Lee¹, Young Jin Lee² and Kwon Soon Lee^{1,*}

¹Dept. of Electrical Eng., Dong-A Univ., 840 Hadan 2-dong, Saha-gu, Busan, 604-714, S. Korea

²Dept. of Electrical Instrument & Control, Korea Aviation Polytechnic College, Kyungnam, S. Korea

(Manuscript Received December 7, 2007; Revised July 4, 2008; Accepted July 11, 2008)

Abstract

This paper presents a robust control approach for nonlinear uncertain crane systems with a three DOF framework. We deal with an overhead crane in which a trolley located on the top is moved to x - and y -axes independently. We first approximate the nonlinear system model through feedback linearization transformation to simply construct a PD control and then design a robust control system for compensating control deviation feasibly occurring due to modeling error or system perturbation in practice. An adaptive control rule is analytically derived by using Lyapunov stability theory given bounds of system perturbation. We accomplish numerical simulation for evaluating the proposed methodology and demonstrate its superiority by comparing with the traditional control strategy.

Keywords: Crane system; Robust control; System perturbation; Lyapunov theory

1. Introduction

A crane is an important mechanical system in industry for carrying a heavy object to a desired position. Until now, several crane systems have been developed and successfully employed in practice. Moreover, advanced control strategies for such mechanical systems have been investigated to enhance their control performance.

In [1], the authors developed a time-scale separation control method for an overhead crane system and used a linearized model to describe the error dynamics. In [2], the authors proposed a saturating control approach based on a guaranteed control cost for a linearized crane model. Martindale et al. in [3] investigated building exact model information for an approximate crane system modeling and to design an adaptive controller. Moustafa and Ebeid developed a

nonlinear dynamic model for an overhead crane system and applied a linear feedback control based on a linearized state space Eq. [4]. Lee studied nonlinear modeling of an overhead crane system using a new swing-angle definition and an anti-swing control methodology for decoupled linearized dynamic characteristics [5]. More advanced researches for nonlinear dynamics of crane systems have also been addressed more recently. In [6], the authors proposed a passivity-based controller for an under-actuated crane system using an energy-based nonlinear control scheme. Fang *et al.* investigated an energy-based control approach for an overhead system, in which additional nonlinear terms were injected to the controller to increase coupling between the gantry and the payload position [7]. The approach resulted in a significant improvement in the transient response. Hekman and Singhose developed a feedback control method for controlling motor systems to mitigate oscillations of the payload by optimally timing the ensuing on/off motor commands, which is applicable to industrial bridge cranes [8].

[†] This paper was recommended for publication in revised form by Associate Editor Dong Hwan Kim

*Corresponding author. Tel.: +82 51 200 7739, Fax.: +82 51 200 7743

E-mail address: kslee@dau.ac.kr

© KSME & Springer 2008

Most engineers in such researches usually linearized complicated nonlinear system models to simply construct an available control scheme in practice. However, such approximation usually involves system perturbation due to its modeling error in real-time implementation. Moreover, because uncertainty in the cranes significantly deteriorates control performance, a more efficient control strategy is required to overcome such a problem.

We investigate novel adaptive and robust control for a complicated nonlinear crane with a three-DOF framework using Lyapunov-based model reference control design. The dynamic motion is mathematically expressed with an intricate nonlinear differential equation. First, we linearize the system model via feedback linearization transformation, as carried out in previous studies, and then derive a nominal linear control using the linearized system model. Secondly, an auxiliary control scheme is additionally established for compensating system error due to its approximation based on model reference adaptive control algorithm. We also embed robustness against uncertainty of the crane by applying Lyapunov stability theory [9]. Total control input is linearly composed of nominal and corrective control input. We accomplish computer simulation to evaluate the proposed control approach for the perturbed crane system and demonstrate its superiority by comparing with a nominal control method. As well, we prove its robustness against random disturbance exciting the crane.

This paper is organized as follows: Section 2 provides the crane system Eq. and its linearized model. We propose an adaptive and robust crane control method in Section 3. Computer simulation and qualitative comparison are provided in Section 4 and 5, respectively. Lastly conclusion and future work are given in section 6.

2. Crane modeling and linearization

We consider a 3D crane system shown in Fig. 1, in which a trolley in its top carries a payload connected with a rope, and two external forces f_x, f_y are applied to move a trolley against x - and y - axes respectively. Due to swinging of the payload, two swing angles θ_x, θ_y are correspondingly occurring in a rope. In this system, a payload is attached in a spreader where a control actuator is located on it to reduce its swing and control inputs u_x and u_y are applied. A rope l is also considered as a dynamic variable.

We express the dynamic Eq. of the crane system in Fig. 1 by using Lagrange modeling [5] as

$$(m_x + m)\ddot{x} + ml \cos \theta_x \cos \theta_y \ddot{\theta}_x - ml \sin \theta_x \sin \theta_y \ddot{\theta}_y + m \sin \theta_x \cos \theta_y \dot{l} + d_x \dot{x} + 2m \cos \theta_x \cos \theta_y \dot{l} \dot{\theta}_x - 2m \sin \theta_x \sin \theta_y \dot{l} \dot{\theta}_y - ml \sin \theta_x \cos \theta_y \dot{\theta}_x^2 - 2ml \cos \theta_x \sin \theta_y \dot{\theta}_x \dot{\theta}_y - ml \sin \theta_x \cos \theta_y \dot{\theta}_y^2 = f_x \quad (1)$$

$$ml^2 \cos^2 \theta_y \ddot{\theta}_x + ml \cos \theta_x \cos \theta_y \ddot{x} + 2ml \cos^2 \theta_y \dot{l} \dot{\theta}_x - 2ml^2 \sin \theta_y \cos \theta_y \dot{\theta}_x \dot{\theta}_y + mgl \sin \theta_x \cos \theta_y + u_x = 0 \quad (2)$$

$$(m_y + m)\ddot{y} + ml \cos \theta_y \ddot{\theta}_y + m \sin \theta_y \dot{l} + d_y \dot{y} + 2m \cos \theta_y l \ddot{\theta}_y - ml \sin \theta_y \dot{\theta}_y^2 = f_y \quad (3)$$

$$ml^2 \ddot{\theta}_y + ml \cos \theta_y \dot{y} - ml \sin \theta_x \sin \theta_y \ddot{x} + 2ml \dot{l} \dot{\theta}_y + 2ml^2 \cos \theta_y \sin \theta_y \dot{\theta}_x^2 + mgl \cos \theta_x \sin \theta_y + u_y = 0 \quad (4)$$

$$(m_l + m)\ddot{l} + m \sin \theta_x \cos \theta_y \ddot{x} + m \sin \theta_y \dot{y} + d_l \dot{l} - ml \cos^2 \theta_y \dot{\theta}_x^2 - ml \dot{\theta}_y^2 - mg \cos \theta_x \cos \theta_y = f_l \quad (5)$$

where $m_x = m_x + m_l, m_y = m_y + m_l$, and m is mass of a payload, m_l is mass of a rope, and d_x, d_y , and d_l are its damping coefficients. Eq. (1) represents the motion equation of a trolley against the x -axis, and the dynamics of a payload for this motion is expressed in (2). Likewise, the dynamics against the y -axis is given in (3) and (4) respectively, and Eq. (5) provides the motion equation about rope dynamics. External inputs f_x and f_y are excited to a trolley, and control inputs u_x and u_y are generated from a spreader. Thus, this crane system includes two kinds of inputs: one is aimed for controlling position of a crane and the other is to eliminate its swing.

Intuitively, the motion Eqs. in (1)-(5) are somewhat complicated, so it is rarely straightforward to design a controller by using this model. However, for simplicity, we approximate the system equation through feedback linearization approach in the first step of control design. We refer to the approximation law in [5] for such a system model and obtain a linearized system model as

$$(m_x + m)\ddot{x} + d_x \dot{x} + ml \ddot{\theta}_x = f_x \quad (6)$$

$$ml^2 \ddot{\theta}_x + ml \ddot{x} + ml g \theta_x = -u_x \quad (7)$$

$$(m_y + m)\ddot{y} + d_y \dot{y} + ml \ddot{\theta}_y = f_y \quad (8)$$

$$ml^2 \ddot{\theta}_y + ml \dot{y} + ml g \theta_y = -u_y \quad (9)$$

$$(m_l + m)\ddot{l} + d_l \dot{l} - mg = f_l \quad (10)$$

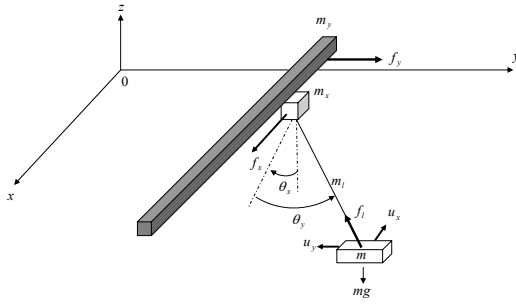

Fig. 1. Geometric model of the three DOF crane system.

Likewise, Eqs. (6) and (7) linearly represent the dynamics of the trolley and payload for *x*-axis, Eqs. (8) and (9) involve its dynamics for *y*-axis direction, and Eq. (10) is approximated for dynamics of the rope. Apparently, both equations are structurally identical, but their dynamics are independent of each other in a linearized model. This means each dynamics is not mutually influenced, but this is not reasonable from a practical point of view. Thus, we must compensate feasible control error due to such approximation.

3. Crane control system

This section describes the design procedure of the control system stated in section 2 for the linearized system model. First, we derive a nominal control and then auxiliary control for compensating of actual control error.

3.1 Design of a nominal control system

We design a nominal control for the linear model in (6)-(10) from a feedback linearization approach. To utilize this method, we rewrite (6)-(9) in vector form as

$$M\ddot{q} + D\dot{q} + G = F \tag{11}$$

and input and state vectors are given by

$$F = \begin{bmatrix} F_x & F_y \end{bmatrix}^T, \quad q = \begin{bmatrix} q_x & q_y \end{bmatrix}^T$$

where

$$F_x = \begin{bmatrix} f_x & -u_x \end{bmatrix}^T, \quad F_y = \begin{bmatrix} f_y & -u_y \end{bmatrix}^T, \quad q_x = \begin{bmatrix} x & \theta_x \end{bmatrix}^T, \\ q_y = \begin{bmatrix} y & \theta_y \end{bmatrix}^T \\ M = \text{diag}\{M_x, M_y\} \in R^{4 \times 4},$$

$$D = \text{diag}\{D_x, D_y\} \in R^{4 \times 4}, \\ G = \text{diag}\{G_x, G_y\} \in R^{4 \times 4} \\ M_x = \begin{bmatrix} m_x + m & ml \\ 1 & l \end{bmatrix}, \quad M_y = \begin{bmatrix} m_y + m & ml \\ 1 & l \end{bmatrix} \\ D_x = \begin{bmatrix} d_x & 0 \\ 0 & 0 \end{bmatrix}, \quad D_y = \begin{bmatrix} d_y & 0 \\ 0 & 0 \end{bmatrix}, \quad G_x = G_y = \begin{bmatrix} 0 & 0 \\ 0 & g \end{bmatrix}$$

Based on the feedback linearization approach, a control vector *F* is defined as

$$F = MU + D\dot{q} + G \tag{12}$$

where a new control input *U* is given by a PD structure, that is,

$$U = K_p(r - q) + K_d(\dot{r} - \dot{q}) = -K_d\dot{q} - K_pq + K_pr \tag{13}$$

where *r* is a reference vector and control parameter matrices *K_p*, *K_d* ∈ *R^{4×4}* are diagonal. Substituting (13) to (12), we have

$$F = M(-K_d\dot{q} - K_pq + K_pr) + D\dot{q} + G \tag{14}$$

and applying (14) to (11), system Eq. is expanded as

$$\ddot{q} + K_d\dot{q} + K_pq - K_pr = 0 \tag{15}$$

This is a typical second differential equation, so we can rewrite to a state-space model with separation of variables:

$$\begin{bmatrix} \dot{q}_1 \\ \dot{q}_2 \end{bmatrix} = \begin{bmatrix} 0_{4 \times 4} & I_{4 \times 4} \\ -K_p & -K_d \end{bmatrix} \begin{bmatrix} q_1 \\ q_2 \end{bmatrix} + \begin{bmatrix} 0_4 \\ K_p \end{bmatrix} r_q \tag{16}$$

From linear system theory, we note its characteristic equation is calculated by

$$\left| sI_{8 \times 8} - \begin{bmatrix} 0_{4 \times 4} & I_{4 \times 4} \\ K_p & K_d \end{bmatrix} \right| = \left| \begin{bmatrix} sI_{4 \times 4} & -I_{4 \times 4} \\ K_p & sI_{4 \times 4} + K_d \end{bmatrix} \right| = 0 \tag{17}$$

where

$$K_p = \text{diag}\{k_{p_1}^x, k_{p_2}^x, k_{p_1}^y, k_{p_2}^y\}, \\ K_d = \text{diag}\{k_{d_1}^x, k_{d_2}^x, k_{d_1}^y, k_{d_2}^y\} \tag{18}$$

Finally, we obtain

$$s^2 + k_{d_1}^x s + k_{p_1}^x = 0, \quad s^2 + k_{d_2}^x s + k_{p_2}^x = 0 \quad (19)$$

$$s^2 + k_{d_1}^y s + k_{p_1}^y = 0, \quad s^2 + k_{d_2}^y s + k_{p_2}^y = 0 \quad (20)$$

We simply determine control parameters by using linear system theory for given control specification.

3.2 System model with uncertainty

As stated above, since real-time control error is possibly occurring by an approximated model, efficient control must be derived to overcome this effect. We propose auxiliary control to enhance control performance against an uncertain system. The uncertain system model is realized by defining parameter perturbation. We consider that matrices M , D , and G in (11) include uncertain factors such that a uncertain system model is expressed by

$$(M + \Delta M)\ddot{q} + (D + \Delta D)\dot{q} + (G + \Delta G) = F \quad (21)$$

where ΔM , ΔD , and ΔG denote corresponding uncertain matrices, respectively. Similarly, the system input vector with uncertain matrices is defined as

$$F = (M + \Delta M)U + (D + \Delta D)\dot{q} + (G + \Delta G) \quad (22)$$

where a PD control input U is linearly composed of a nominal PD control and an auxiliary control input. By applying Δu to the nominal control law in (13), we have

$$(M + \Delta M)\ddot{q} - MU + \Delta D\dot{q} + \Delta G = 0 \quad (23)$$

or simply

$$\ddot{q} + \bar{D}\dot{q} + \bar{\Delta} = \bar{M}\Delta u \quad (24)$$

where

$$\bar{M} = (M + \Delta M)M^{-1}, \quad \bar{D} = (M + \Delta M)M^{-1}\Delta D, \\ \bar{\Delta} = (M + \Delta M)^{-1}\Delta G$$

Applying (22) to (21), the uncertain system model is finally expressed as

$$\ddot{q} + (\bar{M}K_d + \bar{D})\dot{q} + \bar{M}K_p q - \bar{M}K_p r + \bar{\Delta} = \bar{M}\Delta u \quad (25)$$

Likewise, we rewrite (25) to a state-space model as

$$\dot{q} = Aq + B\Delta u + Rr_q - \Delta \quad (26)$$

where

$$A = \begin{bmatrix} 0 & I \\ -\bar{M}K_p & -\bar{M}K_d + \bar{D} \end{bmatrix}, \quad B = \begin{bmatrix} 0 \\ \bar{M} \end{bmatrix}, \quad R = \begin{bmatrix} 0 \\ \bar{M}K_p \end{bmatrix}, \\ \Delta = \begin{bmatrix} 0 \\ \bar{\Delta} \end{bmatrix}$$

3.3 Design of model reference based adaptive control

We use the MRAC approach to derive an auxiliary control against the uncertain system model. This MRAC is aimed to derive control law Δu in (26) for which the uncertain system in (26) follows a reference model defined as

$$\dot{q}_d = A_d q_d + B_d v \quad (27)$$

where v is a constant vector, and size of A_d and B_d is equal to A and B in (27), respectively. A matrix A_d must be Hurwitz (i.e., real part of all eigenvalues is negative) and (A_d, B_d) is controllable. The control law is analytically derived for which an actual system in (26) follows a reference model in (27). That is, an error between these dynamics given by

$$e = q_d - q \quad (28)$$

should be minimized by proper control rule for Δu . We employ Lyapunov stability theory to derive the control law for such a goal. A Lyapunov function candidate is defined as

$$V(e) = e^T P e \quad (29)$$

where a square matrix P should be positive definite such that $V > 0$. Its derivative is simply calculated as

$$\dot{V}(e) = \dot{e}^T P e + e^T P \dot{e} \quad (30)$$

where

$$\dot{e} = \dot{q}_d - \dot{q} \\ = A_d x_d + B_d v - Aq - B\Delta u - Rr_q + \Delta \\ = A_d e + A_d q - (Aq + B\Delta u + Rr_q - \Delta) + B_d v \quad (31)$$

By substituting (31) to (30), we have

$$\dot{V}(e) = \left[e^T A_d^T + q^T A_d^T - (A_q^T + \Delta u^T B^T + r_q^T R^T - \Delta^T) + v^T B_d^T \right] P e + e^T P \left[A_d e + A_d q - (A q + B \Delta u + R r_q - \Delta) + B_d v \right] \quad (32)$$

Finally, the derivative of the Lyapunov function is simply expressed by

$$\dot{V}(e) = e^T (A_d^T P + P A_d) e + 2 \zeta \quad (33)$$

where

$$\zeta = e^T P \left[A_d q - (A q + B \Delta u + R r_q - \Delta) + B_d v \right] \quad (34)$$

We note that scalar \dot{V} should be negative for error convergence from Lyapunov stability theory. We conclude two sufficient conditions to obtain negative \dot{V} as follows:

Condition 1: $A_d^T P + P A_d = -Q$

where Q is positive definite or an identity matrix for simplicity.

Condition 2:

$$e^T P \left[A_d q - (A q + B \Delta u + R r_q - \Delta) + B_d v \right] < 0 \quad (35)$$

We derive the control law of Δu satisfying these two sufficient conditions. For the former, since A_d is stable, we properly select $P > 0$. For the latter, we analytically define Δu to satisfy condition 2, but information about the perturbation is incompletely provided, so it is not straightforward to seek unique solution about Δu . We assume that its bound is defined in design procedure, which is a reasonable consideration in practice.

4. Computer simulation

We conduct computer simulation to demonstrate the reliability of the proposed control approach and its superiority by comparing with traditional control. MATLAB© is utilized for numerical analysis solving the differential equations in (1)-(5) embedded with our controller, where we defined $m_x = m_y = 32$ kg and $m = 160$ kg, respectively. Three simulation scenarios are considered for which system responses are plotted in turn. The first simulation involves the nominal PD control system, and the second includes comparison

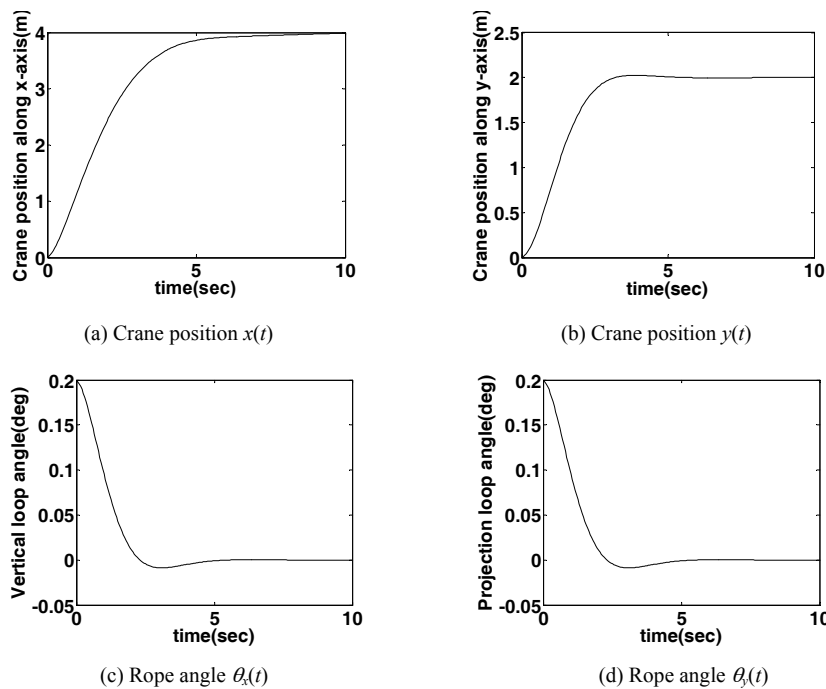

Fig. 2. System responses of the crane with a nominal PD control (Case 1).

of the PD control and our control method against the perturbed crane system. Lastly, we test the robustness of the proposed control exciting random disturbance to the crane. We settle reference values $r_x = 4$ m and $r_y = 2$ m, and control time interval is 10 sec. Maximum length of the rope is 1.5 m and its dynamics versus position $x(t)$ is defined as

$$\begin{cases} l = 1.5x(t), & \text{if } x(t) \in [0,1) \\ l = 1.5, & \text{if } x(t) \in [1,3) \\ l = -1.5x(t) + 6, & \text{if } x(t) \in [3,4] \end{cases} \quad (36)$$

Our control goal is that steady-state error should be zero or close to zero in case of applying a random disturbance, and system response should have no overshoot behavior in the transient region, and minimum rising and settling time.

Case 1: We construct the nominal PD control for the linearized crane system based on the design guideline in section 3. We determine optimal parameter values of the PD control by applying linear system theory for satisfying the given control specification. Fig. 2 shows system responses for this control system. From this result, we observe that the settling time of the response is about 4 sec to 5 sec, and overshoot behavior rarely occurs. As a result, these curves dem-

onstrate satisfactory control performance of the nominal PD control.

Case 2: We apply our control to a perturbed crane system and compare its control performance with the PD control constructed in Case 1. System perturbation is realized as a change of the crane mass within [160, 2160] kg, which is industrially practical. We follow the design guideline in section 3 to derive a robust control system and regard the maximum loading mass the crane feasibly carries, as supreme for the system perturbation. Fig. 3 shows system responses for the two controls against the perturbed crane. In the PD control, system response never reaches a steady-state region in a given time interval. This result numerically proves that the PD control constructed under the nominal environment is not properly accomplished against the perturbed system. By contrast, in our control system, steady-state responses of both rope and crane are converged to the reference values around 3 sec, respectively. Consequently, it is obvious from the comparison that the proposed control outperforms.

Case 3: We apply a random disturbance to the crane system to demonstrate the robustness of our control system. Wind force usually excites crane systems as an environmental disturbance in marine ports equipped with such cranes. In practical implementation, robust crane control is therefore significantly

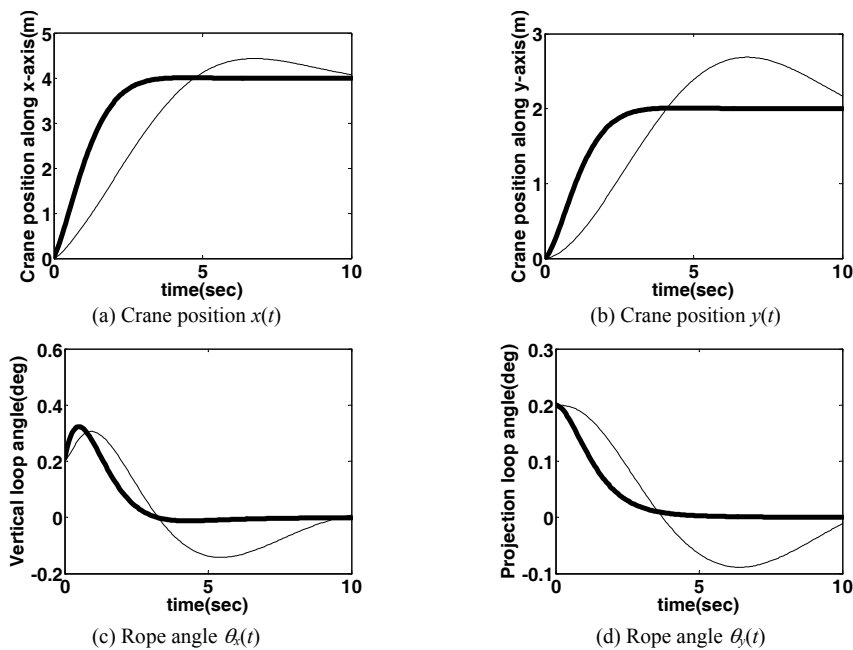

Fig. 3. System responses of the crane with a nominal PD (thin line) and our control (bold line) (Case 2).

required. We settle that disturbance $w(t)$ is zero mean Gaussian with variance $\sigma = 10$, i.e., mathematically, $w(t) \sim N(0,10)$, whose curve is plotted in Fig. 4. This simulation environment is similar to that in Case 1 and we compare both controls likewise. Their system responses are plotted in Fig. 5, from which we obviously recognize that the proposed control is superior to the PD control. As in Case 2, the nominal PD control is not suitably performed within the time interval. In our control, small ripples are occurring in the equilibrium region, but the nature due to the random disturbance is tolerable. From this simulation its dynamics is remarkably robust against the disturbance.

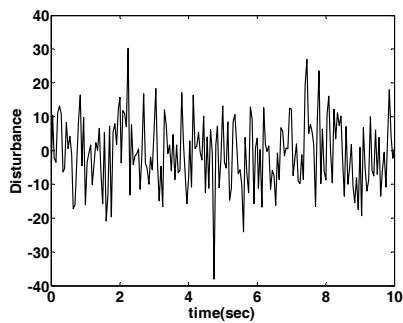

Fig. 4. Random disturbance excited to the crane.

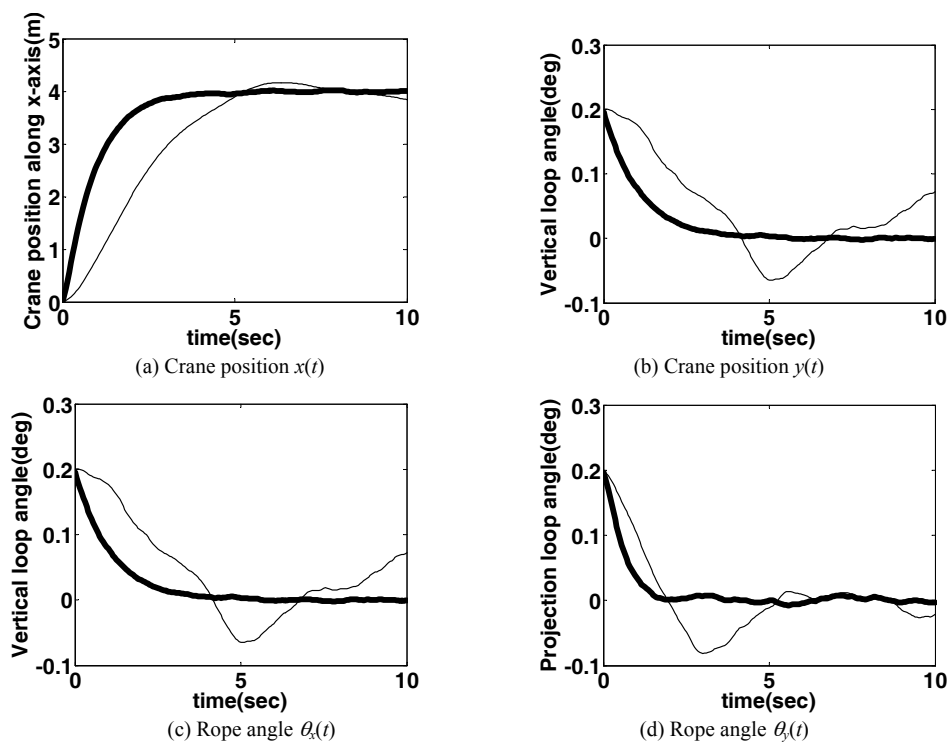

Fig. 5. System responses of the crane with a nominal PD (thin line) and our control (bold line) (Case 3).

5. Qualitative comparison to the recently addressed control approaches

This section provides a qualitative comparison to more recently proposed crane control strategies [5, 10, 11]. In [5, 10], and [11], the authors developed advanced control methodology of the cranes for precise position control and effective anti-swing strategy.

In [5], the author similarly approximated the complicated system model with the assumption that the crane is slowly moving while operating. A linear system model is used for constructing linear control through classical control design guidelines. The author established a test-bed for the crane control system to evaluate the proposed control approach via real-time experiment. In [10], a predictive control method is presented for a 3D crane system in which a well-known Kalman filter modeling is derived to estimate its dynamics. The authors used a crane simulator to test the effectiveness of their control algorithm through real-time experimental implementation. Most recently, in [11] the authors built a rotary machine in the crane system to suppress oscillation behavior, which works as an active vibration controller.

Table 1. Qualitative comparison to the recently addressed crane control approaches[5, 10, 11].

| Methodology | System performance | | | Robustness testing |
|-------------|--------------------|---------------|--------------------|--|
| | Overshoot | Settling time | Steady-state error | |
| [5] | 0 % | 8 sec | 0 % | None |
| [10] | 20 % | 5 sec | 10 % | None |
| [11] | 0 % | 10 sec | 5 % | None |
| Our control | 0 % | 3 sec | 0 % | Random disturbance Parameter change |

The active rotary machine is simply operated by on-off control strategy, and from real-time experiment they demonstrated its effective performance for mitigating swing of the payload in the crane.

These papers are mostly focused on evaluating their control approaches without disturbance excitation in an experimental procedure. In other words, they sidestepped testing of controller robustness against environmental disturbance. Although their experimental results are satisfying under an undisturbed environment, it is hardly guaranteed to obtain desired control performance against unexpected disturbance. We analytically compare our control performance to these advanced control approaches with respect to transient and steady-state behaviors. Table 1 summarizes this qualitative comparison.

6. Conclusion

This paper presents an adaptive and robust control methodology for a three-DOF crane system whose mathematical model is expressed with complicated nonlinear differential equations. We first approximate the system Eq. to a nominal linear model by using feedback linearization method and then design a nominal PD control. To compensate for real-time control error due to model approximation and parameter perturbation, we propose a corrective control law which is derived from Lyapunov theory, providing partially known information about system perturbation. We numerically illustrate the superiority of our control method via simulation experiments and provide a comparative study with the traditional control method. Future work includes a real-time experiment by using a crane simulator embedded with our

control strategy to verify its applicability in practical implementation.

Acknowledgment

This research was supported by the Ministry of Knowledge and Economy, Republic of Korea, under the ITRC (Information Technology Research Center) support program supervised by IITA (Institute for Information Technology Advancement) (IITA-2008-C1090-0801-0004).

References

- [1] J. Yu, F. L. Lewis and T. Huang, Nonlinear feedback control of a gantry crane, *Proc. of American Control Conference*, (1995) 4310-4315.
- [2] K. Yoshida and H. Kawabe, A design of saturating control with a guaranteed cost and its application to the crane control systems, *IEEE Trans. on Automatic Control*, 37 (1992) 121-127.
- [3] S. C. Martindale, D. M. Dawson, J. Zhu and C. Rahn, Approximate nonlinear control for a two degree of freedom overhead crane: theory and experimentation, *Proc. of American Control Conference*, (1995) 301-305.
- [4] K. A. F. Moustafa and A. M. Ebeid, Nonlinear modeling and control of overhead crane load sway, *J. of Dynamic Systems, Measurement, and Control*, 110 (1988) 266-271.
- [5] H. Lee, Modeling and control of a three-dimensional overhead cranes, *J. of Dynamic Systems, Measurement, and Control*, 120 (1998) 471-476.
- [6] I. Fantoni, R. Lozano and M. W. Spong, Energy based control of the pendubot, *IEEE Trans. on Automatic Control*, 45 (2000) 725-729.
- [7] Y. Fang, E. Zergeroglu, W. E. Dixon and D. M. Dawson, Nonlinear coupling control laws for an overhead crane system, *Proc. of IEEE Conf. on Control Applications*, (2001) 639-644.
- [8] K. A. Hekman and W. E. Singhose, A feedback control system for suppressing crane oscillations with on-off motors, *Int. J. of Control, Automation, & Systems*, 5(3) (2007) 223-233.
- [9] H. Khalil, *Nonlinear systems*, Pearson Higher Education, (2002).
- [10] J. Deng and V. M. Becerra, Application of constrained predictive control on a 3D system, *Proc. Of the IEEE Conf. on Robotics, Automation and Mechatronics*, Singapore, (2004) 583-587.

- [11] K. A. Hekman and W. E. Singhose, A feedback control system for suppressing crane oscillations with on-off motors, *Int. J. of Control, Automation, & Systems*, 5(3) (2007) 223-233.



Hyun Cheol Cho received a B.S. from the Pukyong National University in 1997, a M.S. from the Dong-A University, Korea in 1999, and a Ph.D. from University of Nevada-Reno, USA in 2006. He is currently a post-doc researcher in the Dept. of

Electrical Engineering, Dong-A University. His research interests are in the areas of control systems, neural networks, stochastic process, and signal processing.